

TIM SMITH

RIVA WINE SET
RED CROSS SHOVEL
FORWARD DRAW PISTOL HOLSTER
REMINGTON SURVIVAL KIT
TILITE WHEELCHAIR L.E.D.
COMPUTER MOUSE

Riva

RIVA BOATS ARE SEXY.



SEXY BOATS SHOULD HAVE SEXY ACCESSORIES.



MATERIALS

RIVA BLUE

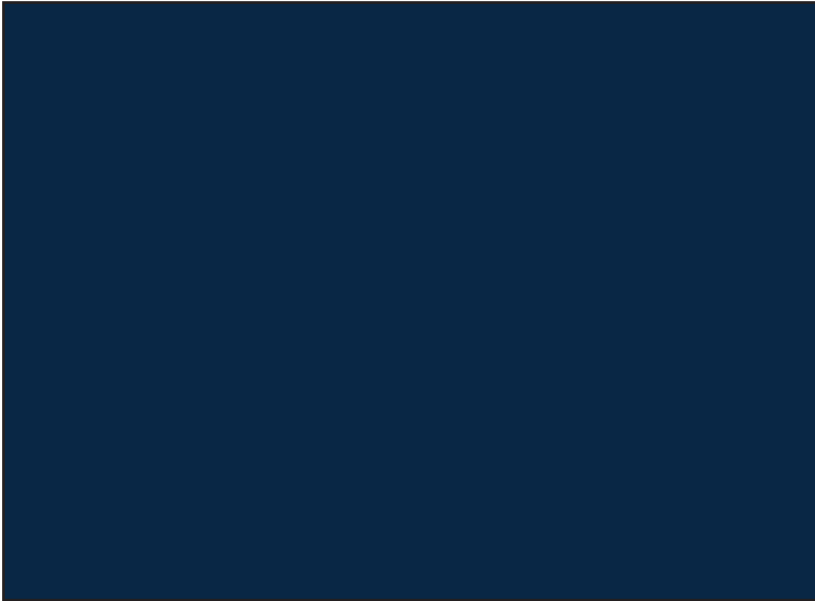

MAHOGANY



STAINLESS STEEL



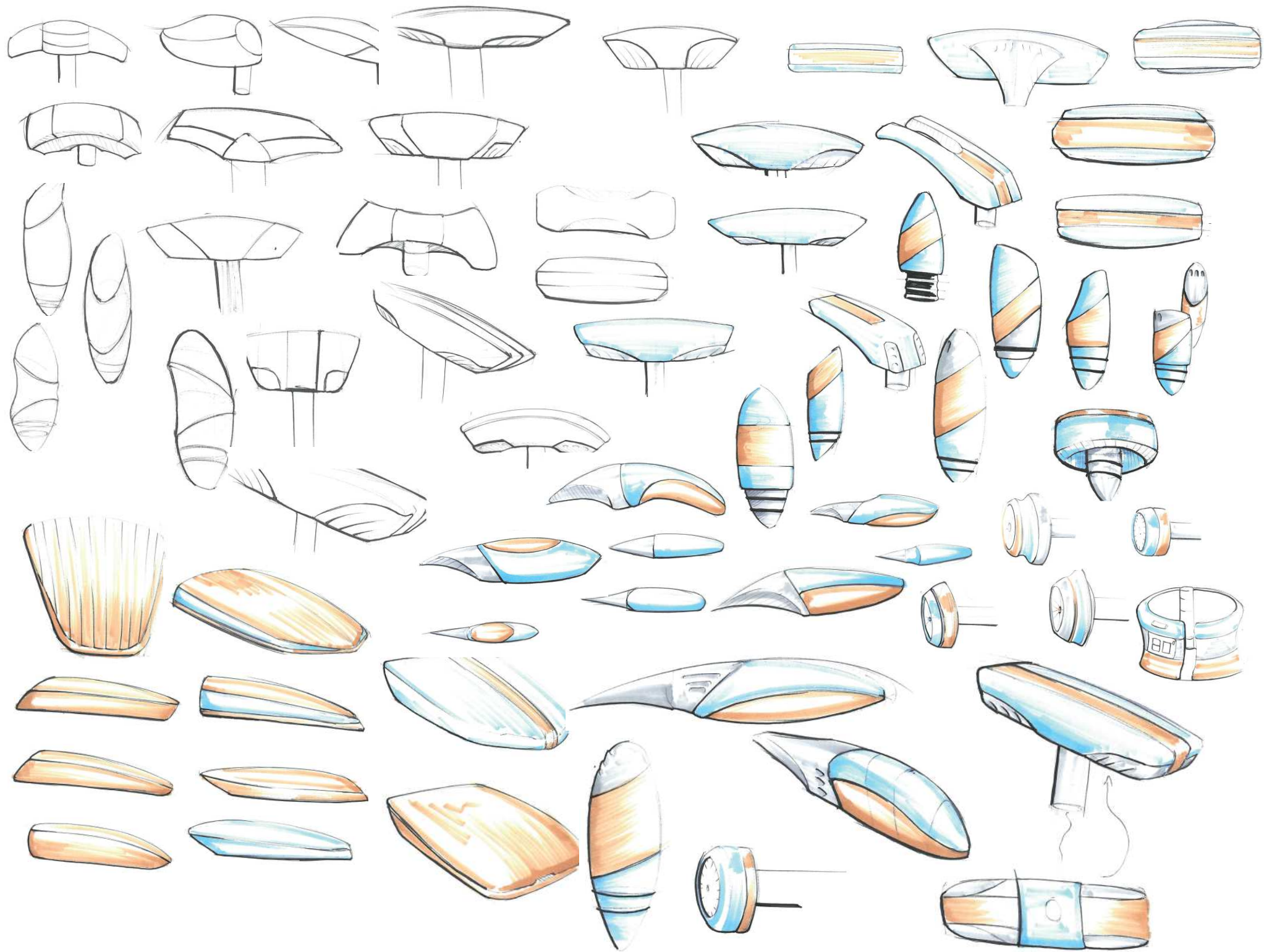

CORKSCREW

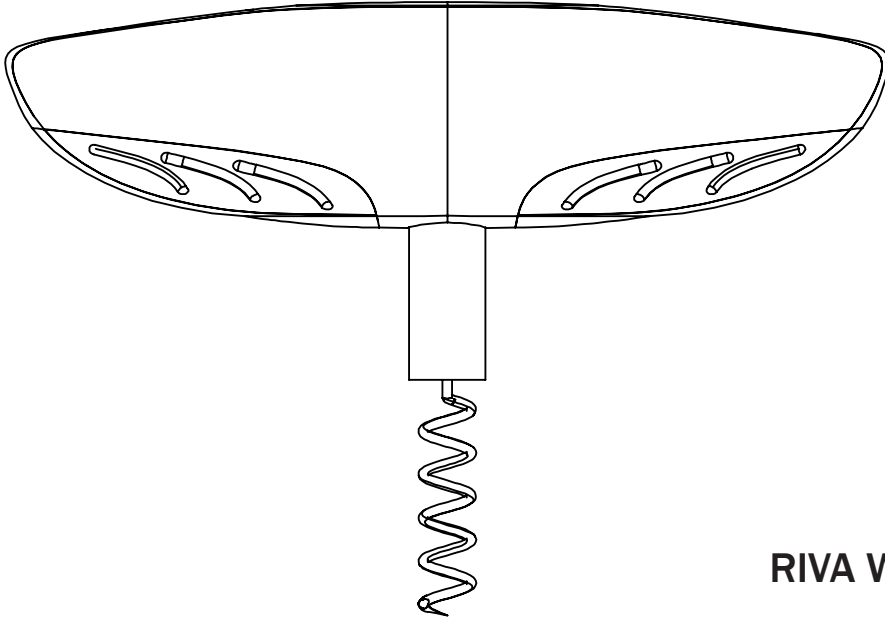

BOTTLE STOP

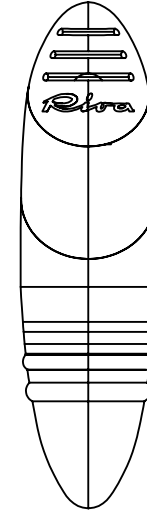

RIVA WINE SET

FOIL CUTTER

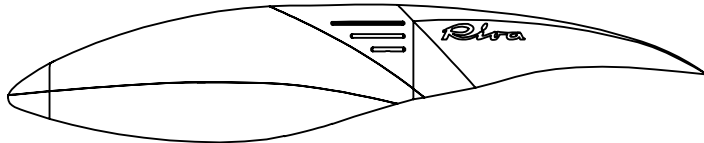

THERMOMETER

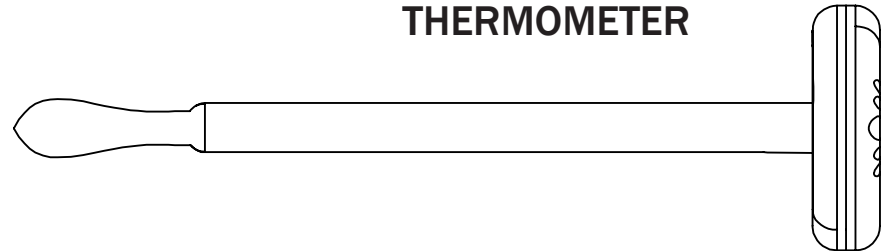

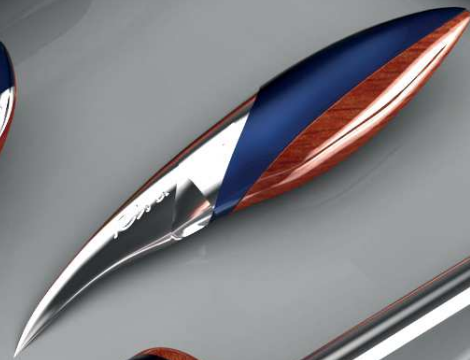
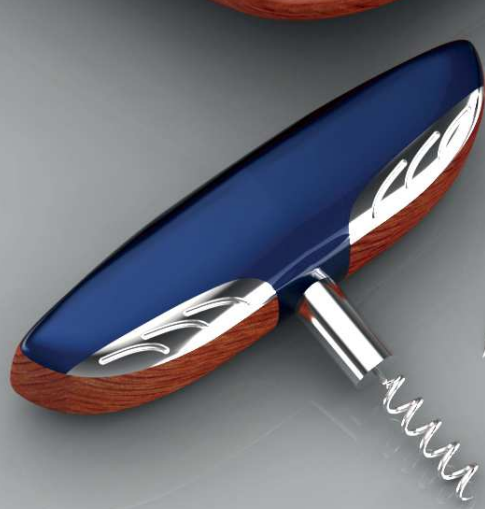



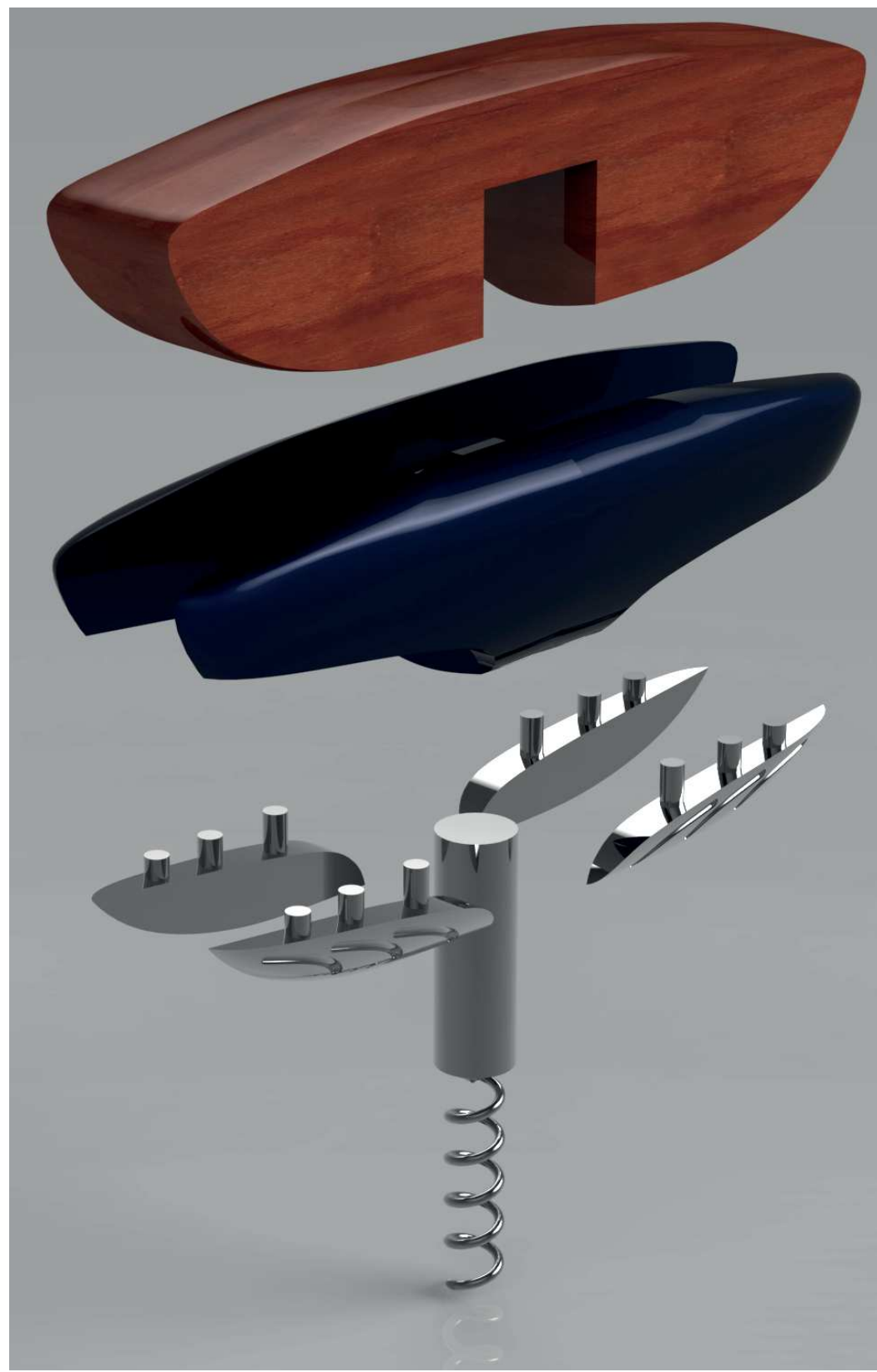





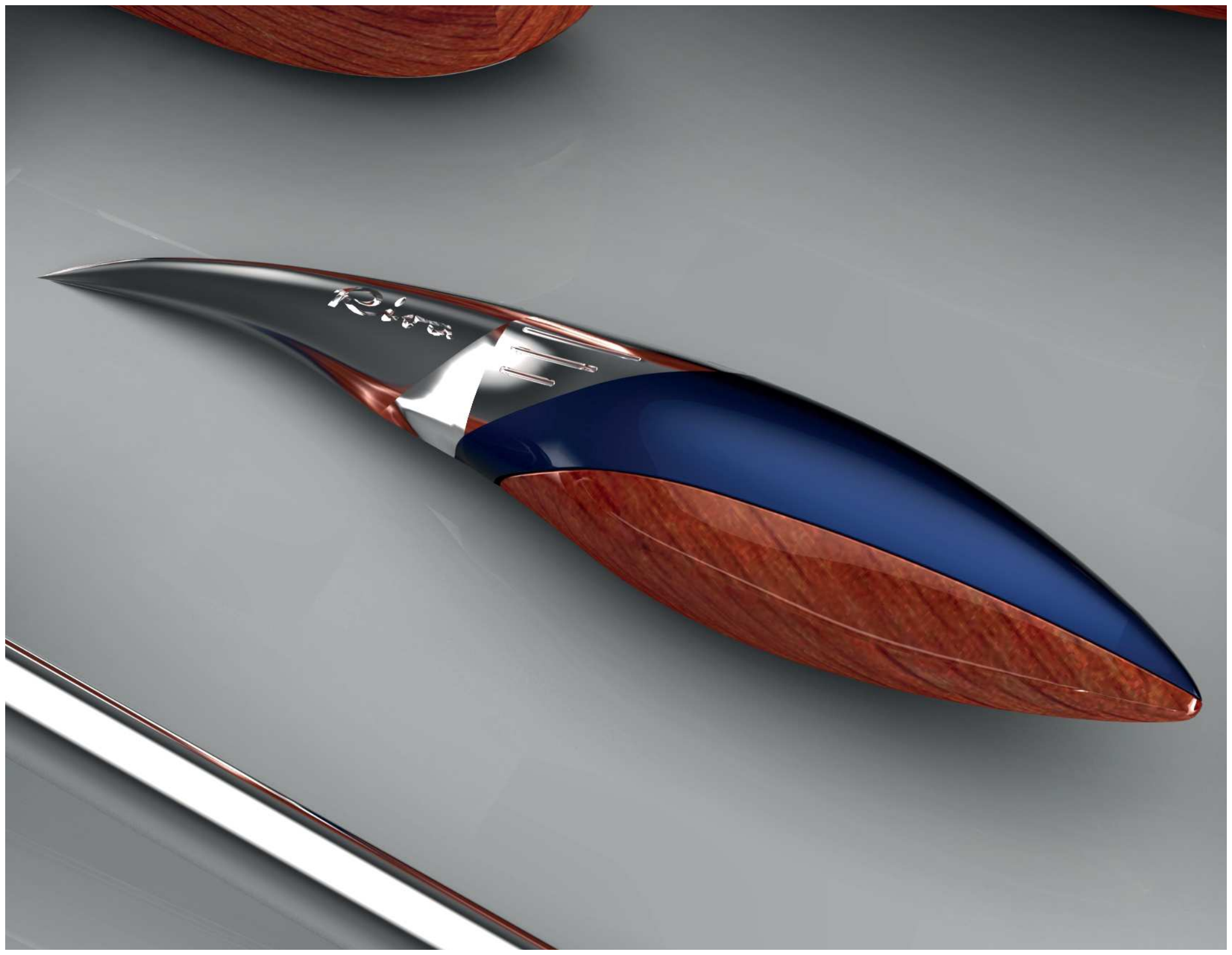

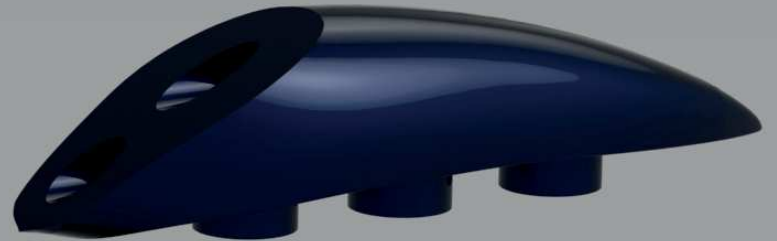
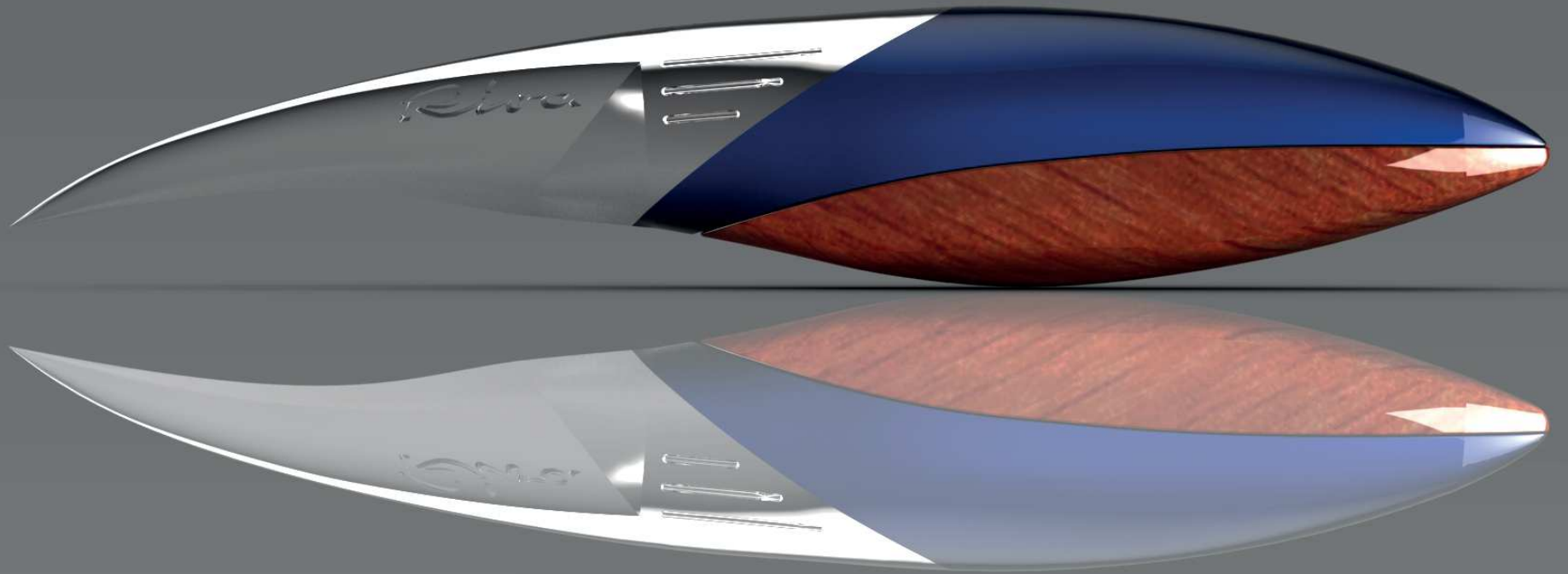









WE BUILT THEM.







RED CROSS NEEDS HELP

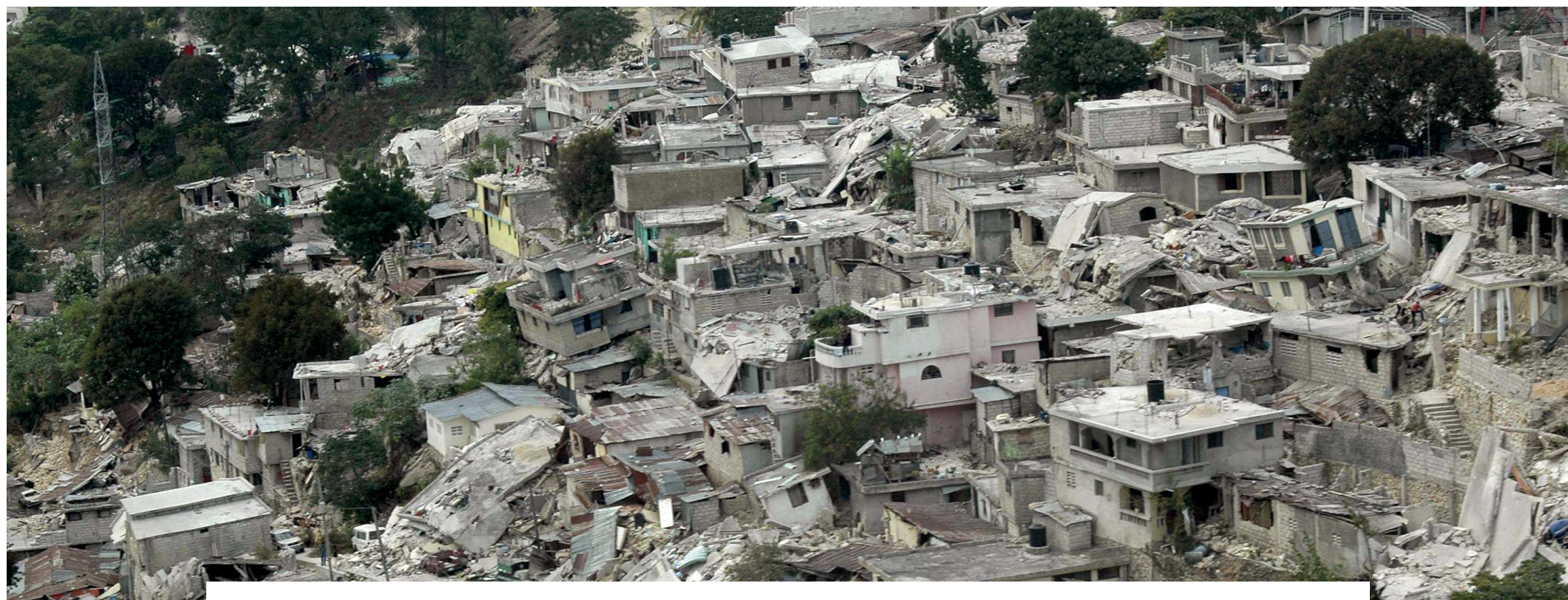

NATURAL DISASTERS LEAVE A DEVESTATING SCENE. THEY NEED TO BE CLEANED UP.



A collection of tools and supplies laid out on a grey surface. From left to right: a shovel with a yellow handle and a black head; a green rope; a hand saw with a yellow handle; a hammer with a wooden handle; a pile of nails; a bag of supplies with a red cross and crescent logo; a small metal tool; a hammer with a wooden handle; a wire mesh; and a small piece of brown paper.

**AID KIT SHOVELS HAVE TO BE COMPACT.
SHORT SHOVELS ARE HARD ON THE BODY.
WE NEED A MORE COMFORTABLE SHORT SHOVEL.**

**INTERNATIONAL FEDERATION OF RED CROSS
AND RED CRESCENT SOCIETIES**

IFRC Regional Logistic Unit Panama

Area de Eventos de Kobbe, Edificio 340, Finca

de Howard, Panama City, Panamá

KITS consisting of the following:

Rope, 30 m long x 12 mm diameter

wooden handle, 750mm approx.

of galvanized steel 75mm x 3.75mm and galvanized

shovel with wooden handle

1.5kg x 1.5kg x 1.5kg 20 x 17 x 4-2mm long steel wire with wooden handle

1 Machete, Curved

1 Tin Snips

500gr Common steel Nails 75mm x 3.75mm

1 Roll of Tie Wire-5 mtr Roll x 2mm diameter

1 Claw hammer, 0.750kg with wooden handle

1 New Woven PP Bag

Gross Weight: 10.5Kgs

CONSIGNMENT TRACKING NUMBER (CTN)-08-0001430

"HUMANITARIAN AID NO COMMERCIAL VALUE"

Bicep
Curl

Bicep Strain

Angle allows
use of
entire back
Chain of
muscles

Retrofittable

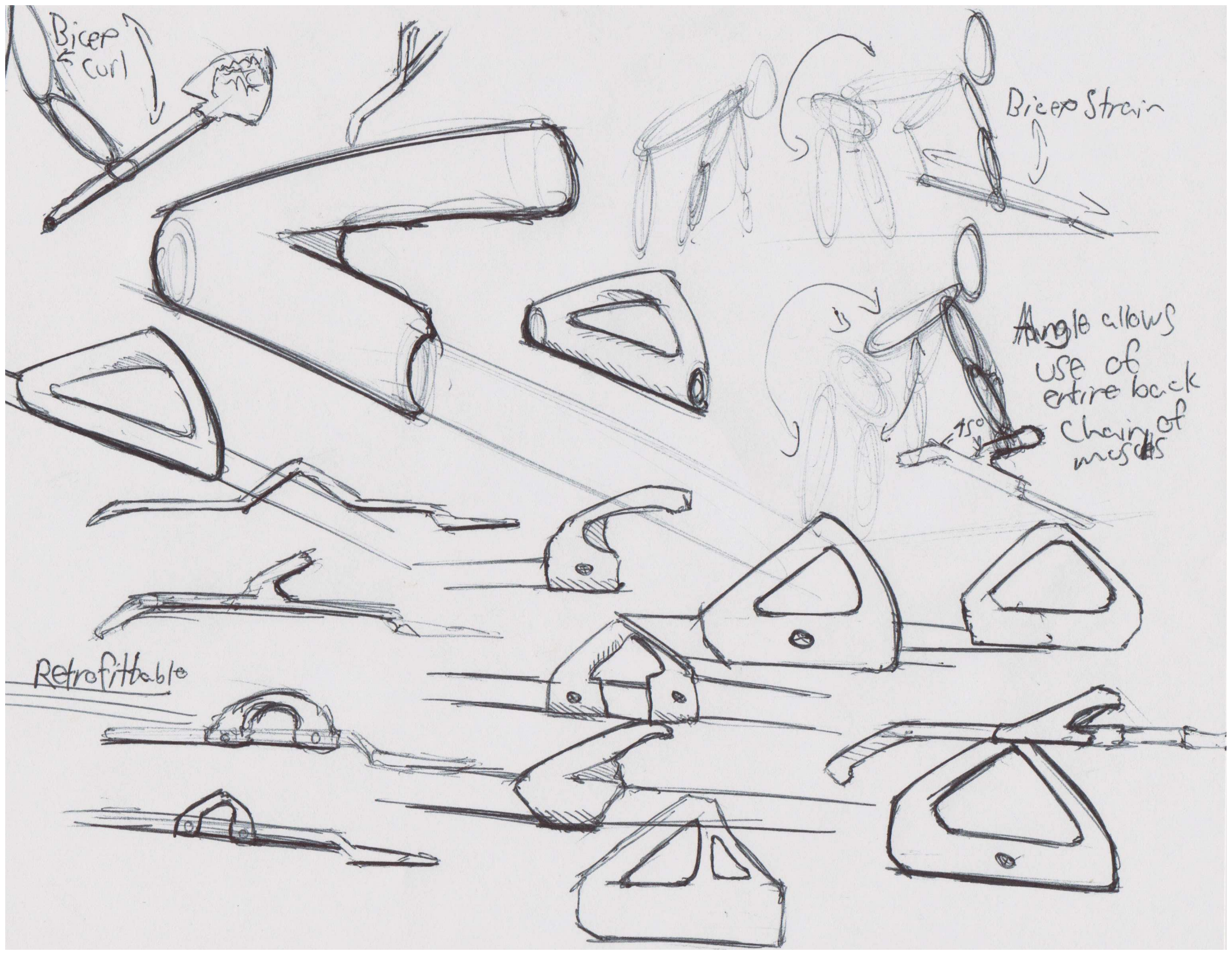

A RAISED, ANGLED GRIP MINIMIZES RANGE OF MOTION BENDING OVER AND UTILIZES TRAP, LAT AND REAR DELTOID TO TAKE SOME STRAIN AWAY FROM THE BICEP





HEALTHIER WRIST POSITION.





TEST MODELS.





QUICK DRAW PISTOL HOLSTER
BECAUSE CURRENT HOLSTERS ARE SLOW

Current holsters require drawing the pistol vertically before bringing it into position. While beneficial in close quarters, I don't think it is necessary.

There are no current level 2 or above holsters that are activated by anything other than thumb or trigger finger. This doesn't feel natural.



MOST POPULAR: SERPA

**REQUIRES PRESSING TRIGGER
FINGER TOWARDS PISTOL FOR
RELEASE.**

DANGEROUS

**PRESSING BUTTON WITH
TRIGGER FINGER CAN RESULT
IN PULLING PRESSURE ON
TRIGGER WHEN IT IS CLEARED
FROM HOLSTER.**

**THAT'S HOW YOU SHOOT
YOURSELF.**



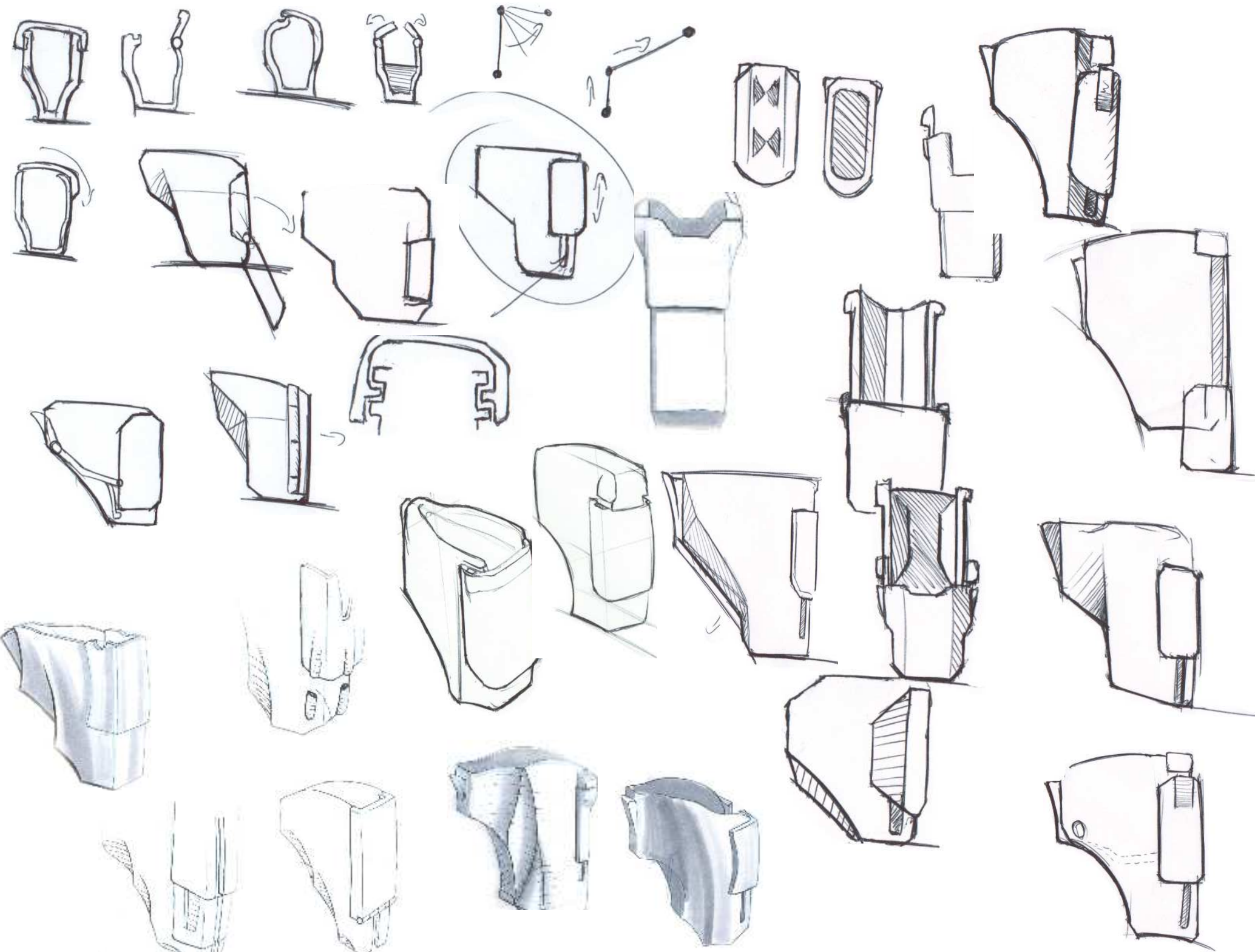

**FUN FACT: FORMER NAVY SEAL
HELPED WITH TESTING.**



SLOWER





FASTER













**GRIP FINGER
ACTIVATED**

**MAGNET DRIVEN
SLIDER**



Remington®

ASKED US TO HELP THEM START A NEW LINE OF CAMPING GEAR.

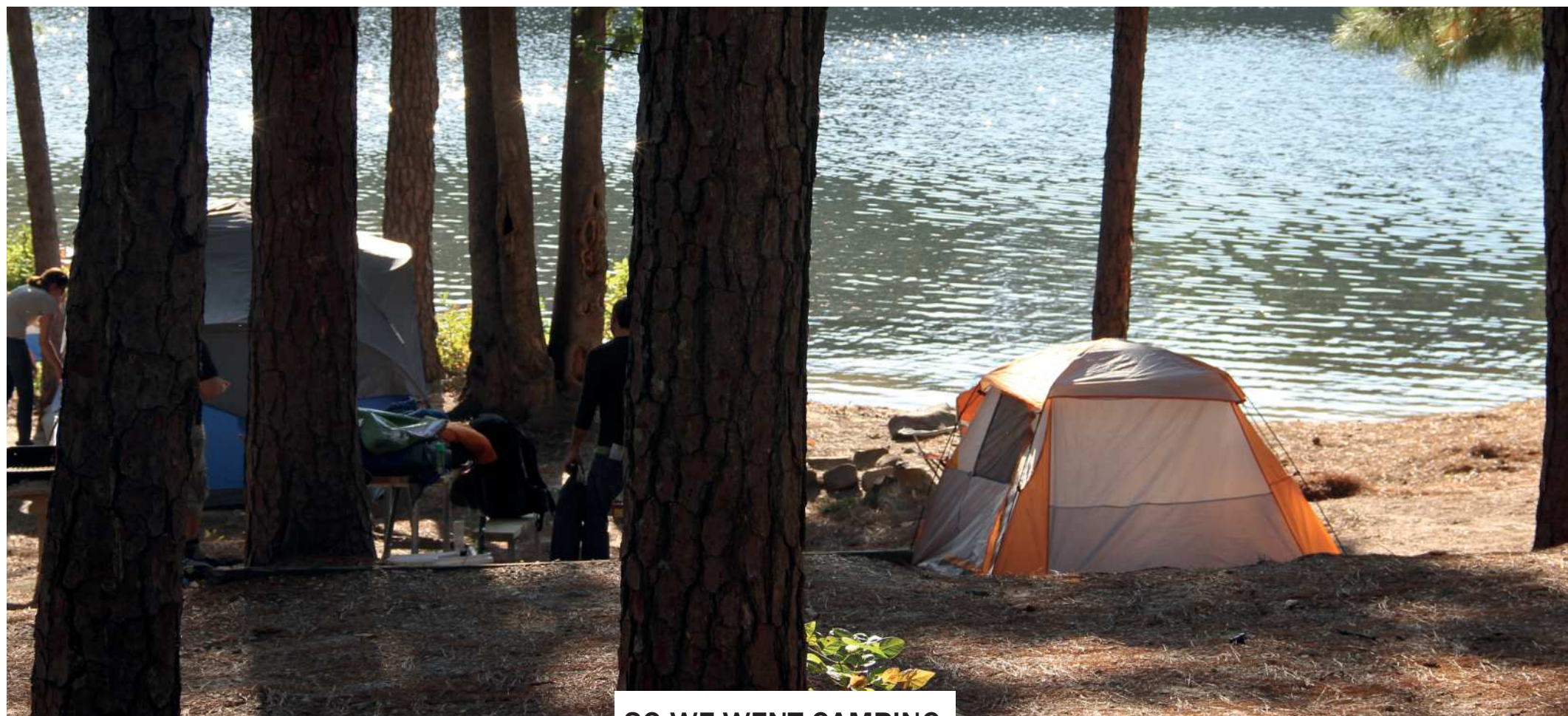

SO WE WENT CAMPING.



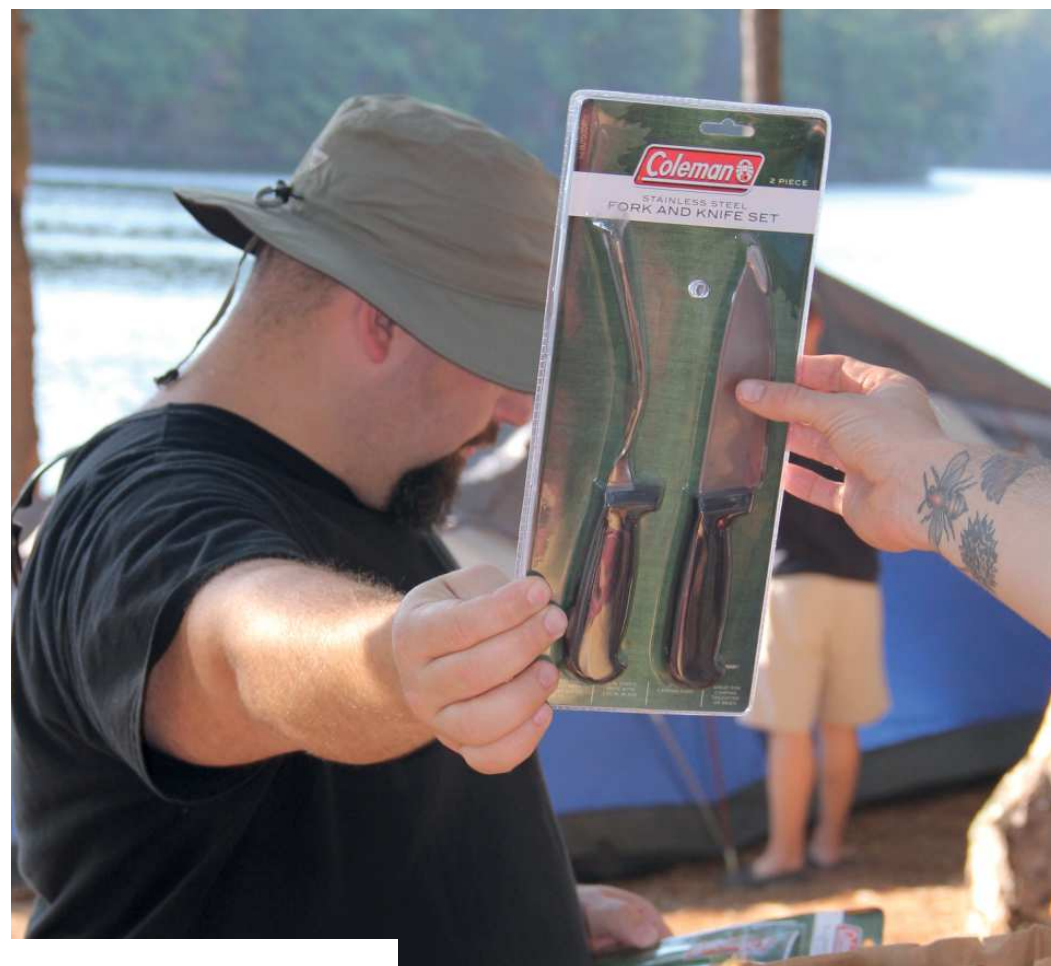

THERE WERE A LOT OF TOOLS TO BRING.

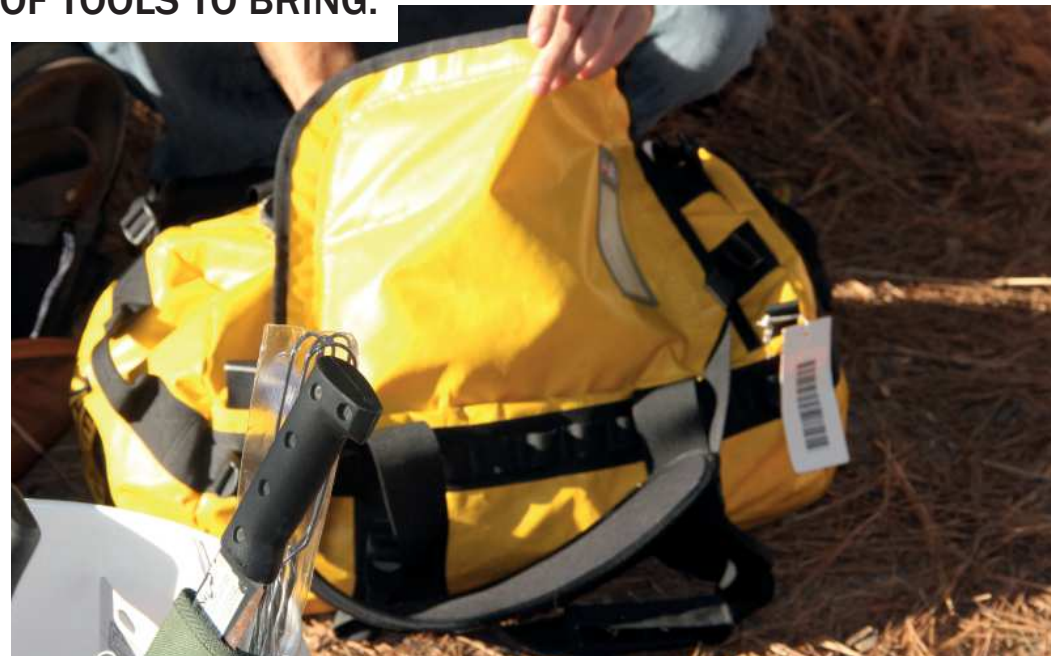



WE DECIDED TO TAKE ALL OF THESE...



I HELPED OUR TEAM CREATE
SOME COOL TOOLS...



WIND UP AND SOLAR POWERED RADIO

MODULAR POTS



MINIATURE STOVE







BUT I WAS MOST HEAVILY INVOLVED WITH THIS



(ANIMATION CAN BE SEEN AT WWW.TIMSMITHID.COM)

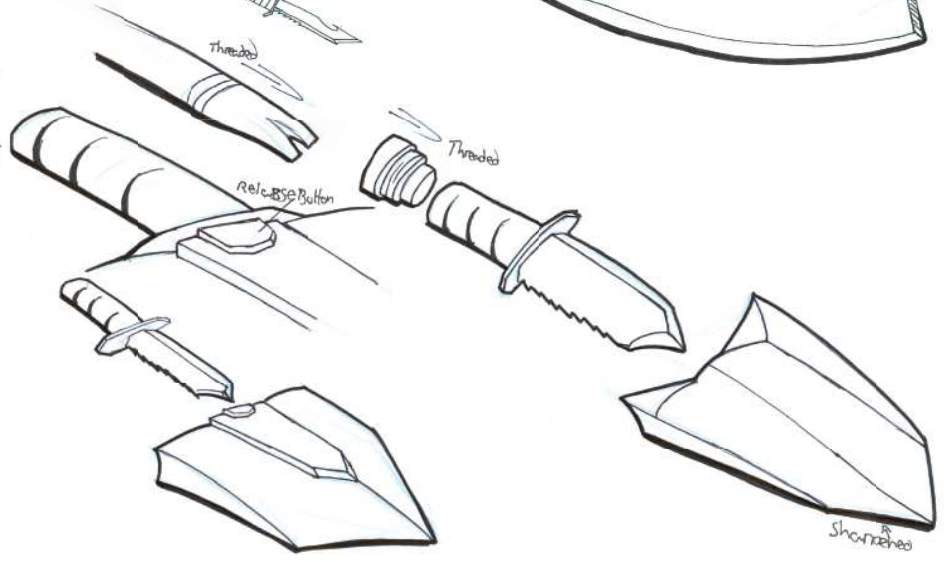
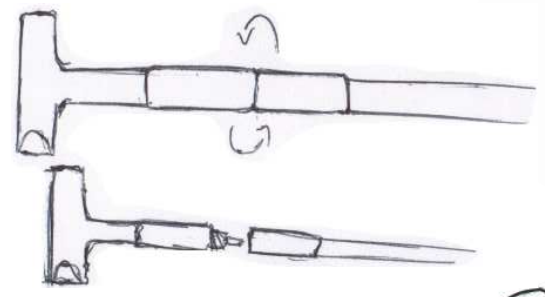
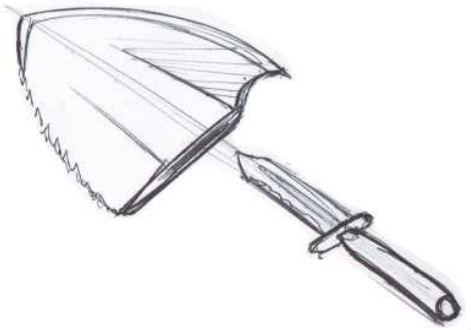
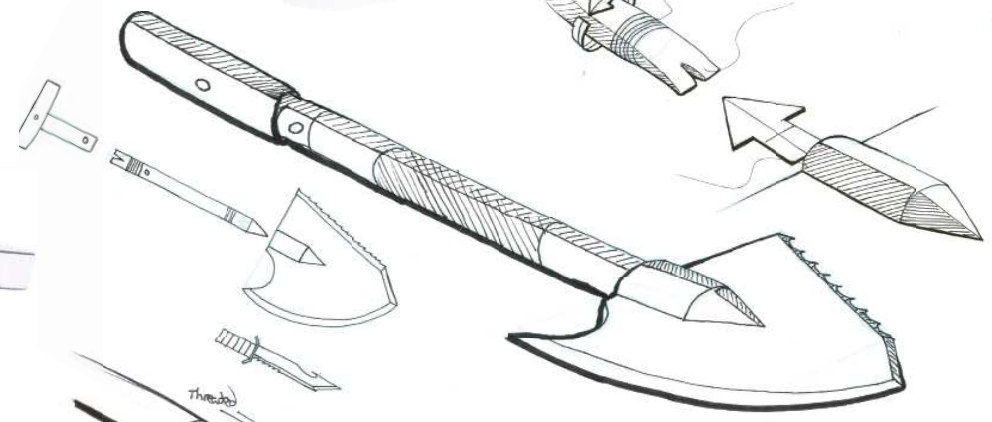
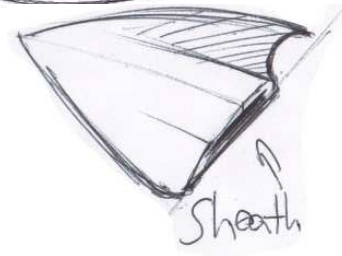
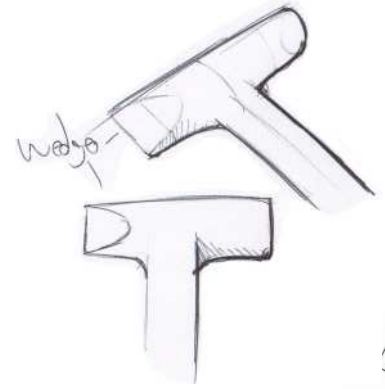
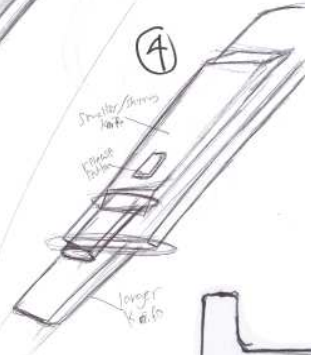
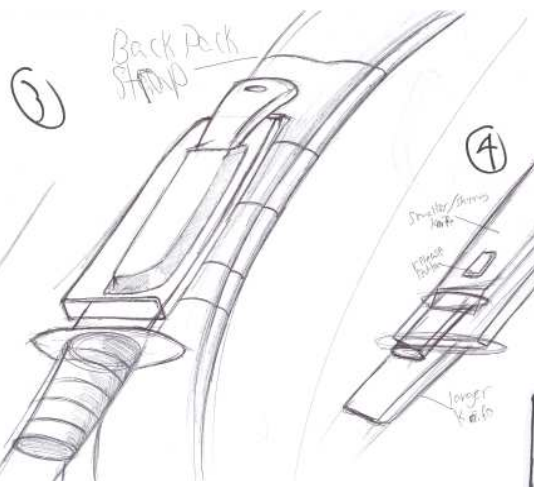
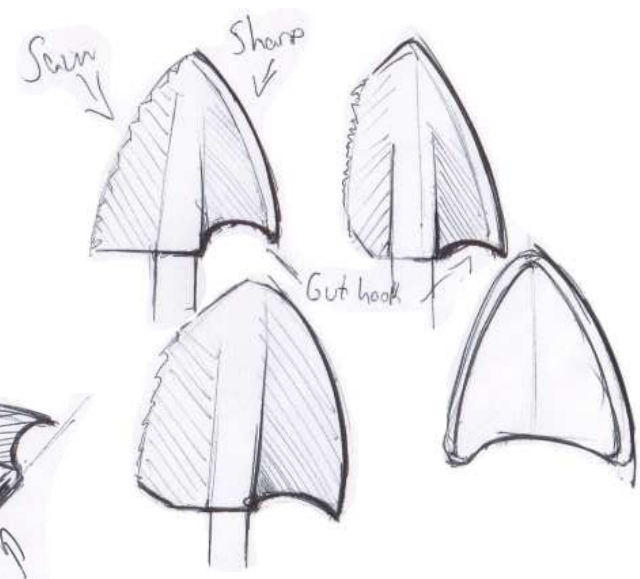
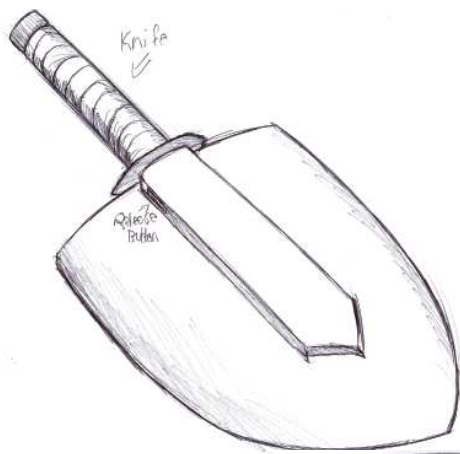
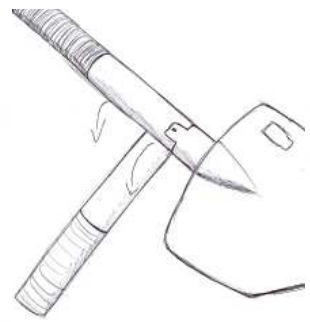
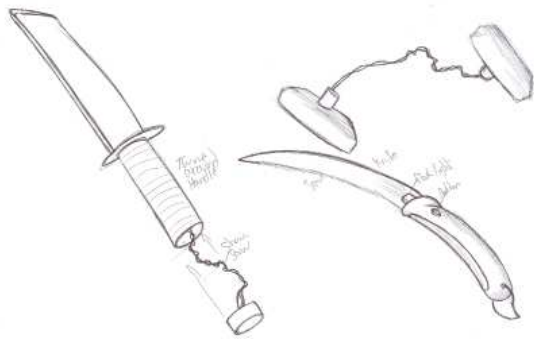

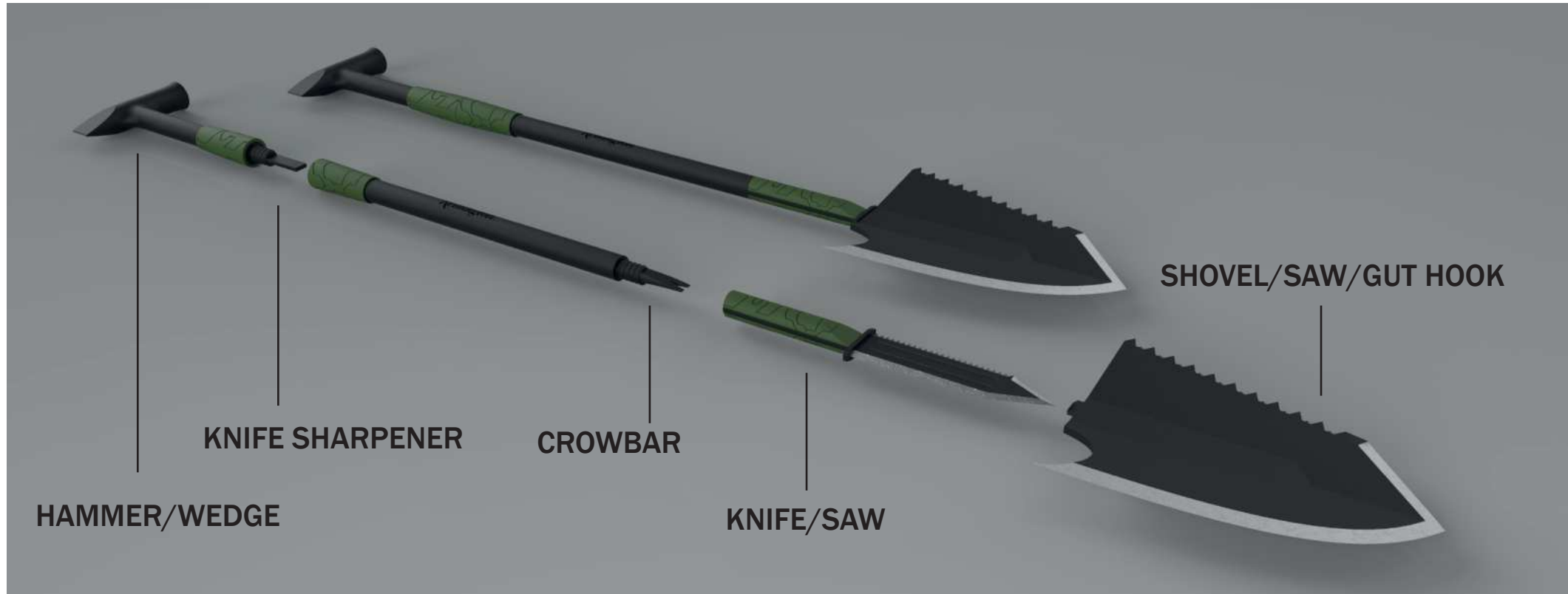

HAMMER/WEDGE

KNIFE SHARPENER

CROWBAR

KNIFE/SAW

SHOVEL/SAW/GUT HOOK









TILITE WANTED TO BE THE FIRST MANUAL WHEELCHAIR BRAND WITH L.E.D. HEADLIGHTS

WHY?

HELP THE USER SEE SMALL OBSTACLES IN LOW LIGHT CONDITIONS.

HELP DRIVERS SEE THE USER IN LOW LIGHT CONDITIONS.

TO LOOK REALLY COOL IN ALL LIGHT CONDITIONS.

THE HARD PART

TILITE WHEELCHAIRS ARE CUSTOM MANUFACTURED.

DIMENSIONS, NUMBER OF ACCESSORIES AND TYPES OF ACCESSORIES VARY.

ANY NEW PRODUCT NEEDS TO WORK WITH ALL AVAILABLE COMBINATIONS.

ACCESSORIES NEED TO BE AS LIGHT WEIGHT AS POSSIBLE.



I WAS GIVEN THIS BUTTON SWITCH AND TASKED WITH CREATING
A HOUSING THAT COULD BE MOUNTED ON EVERY POSSIBLE
WHEELCHAIR SETUP.

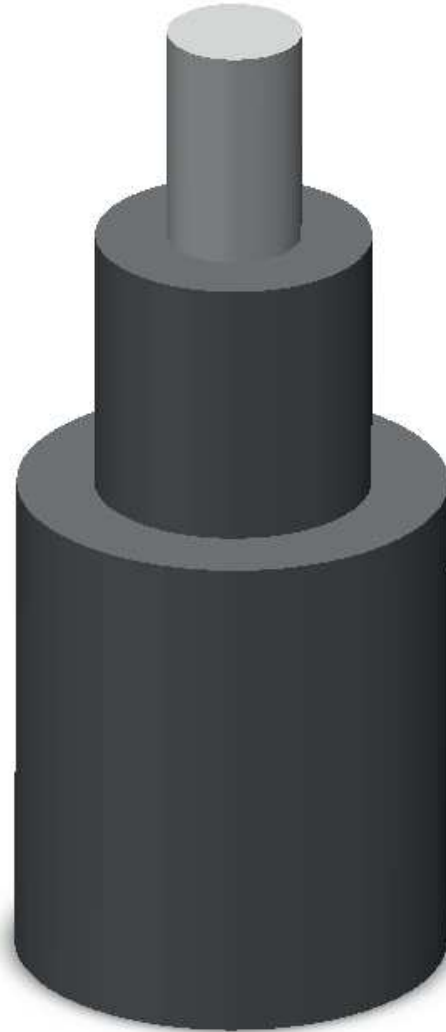

OVERSIZED ELASTOMER OVERMOLDED BUTTON
ANGLED 30 DEGREES AWAY FROM FRAME FOR
USERS WITH LIMITED HAND FUNCTION

DELRIN SUBSTRATE

MULTIPLE SIZE SETTINGS FOR DIFFERENT DIAMETER FRAMES

ELASTOMER OVERMOLDED STRAP

DELRIN ANCHOR FOR ELASTOMOR STRAP

L.E.D. BATTERY LIFE INDICATOR

2"

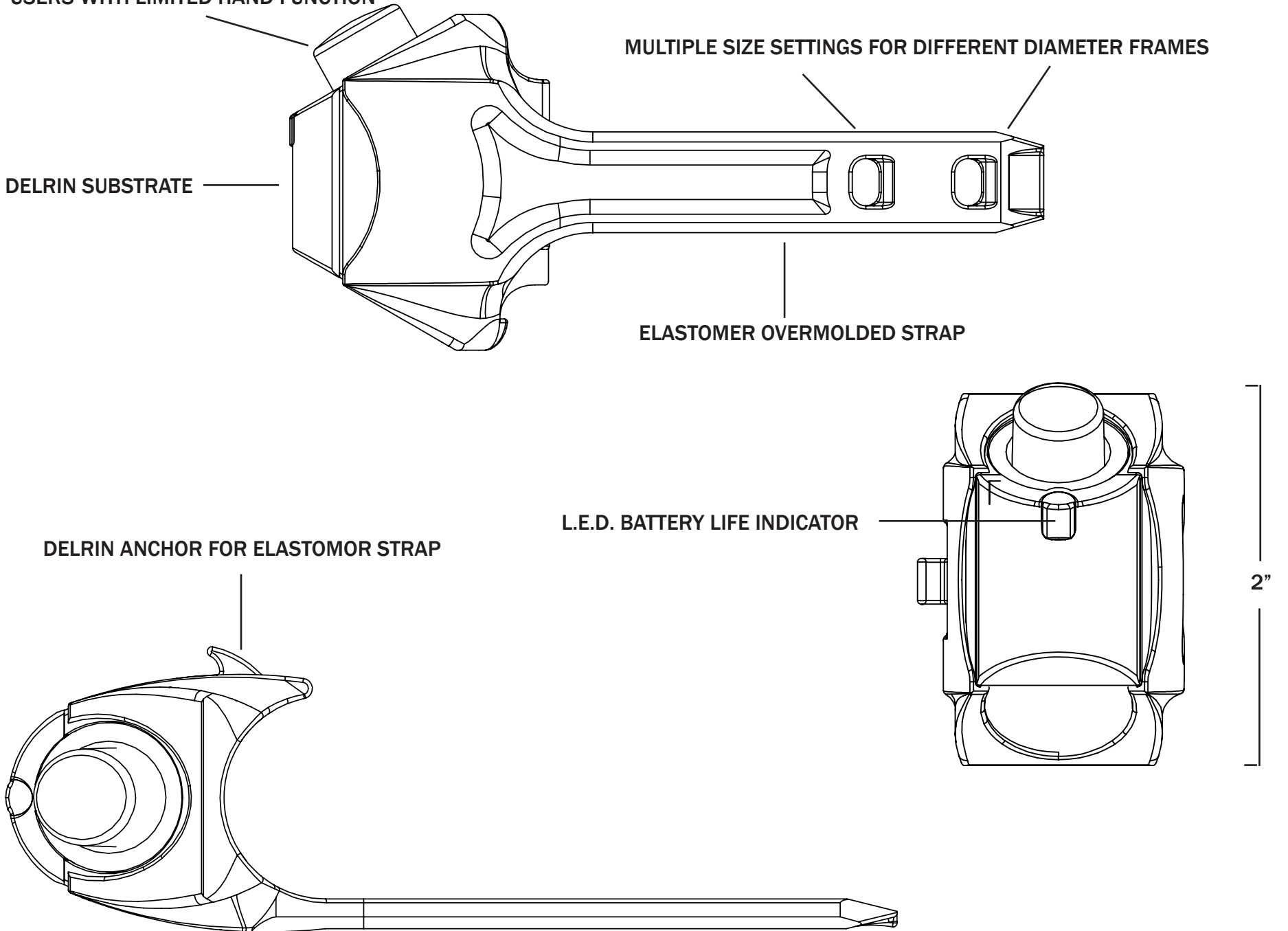



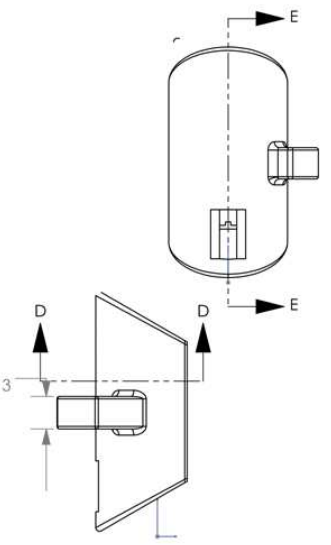
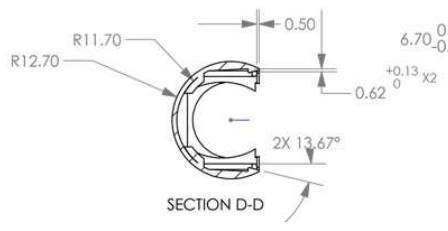
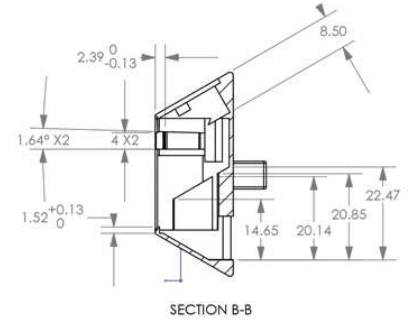
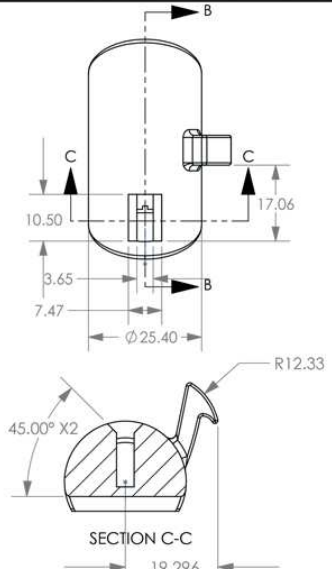
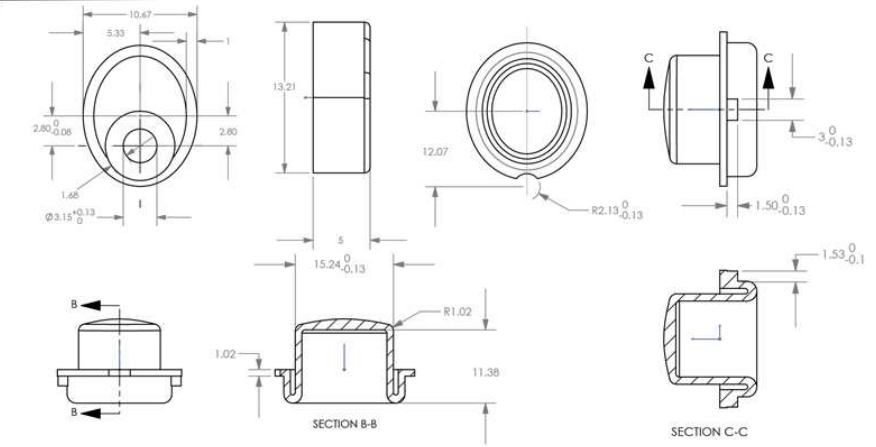
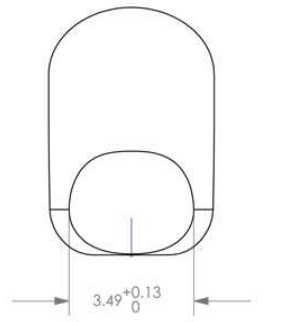
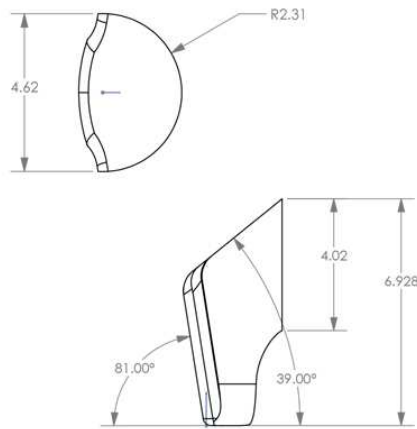
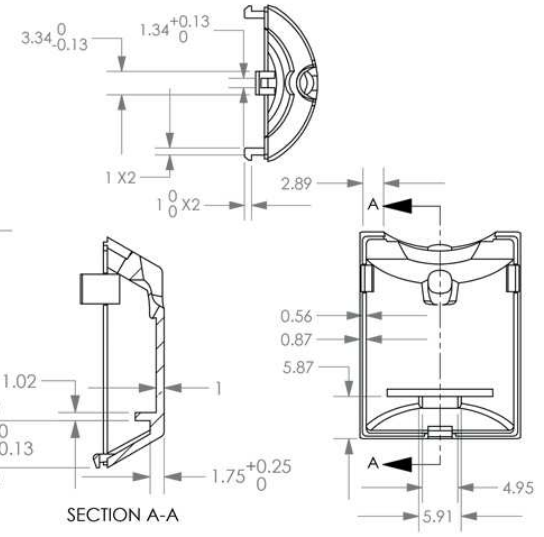
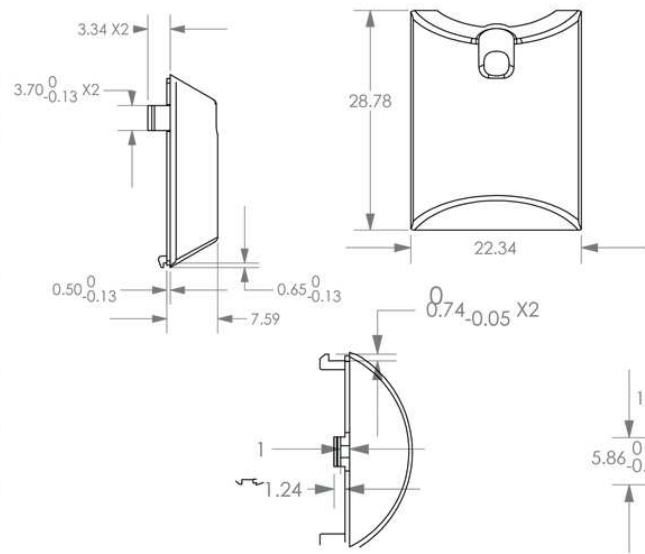
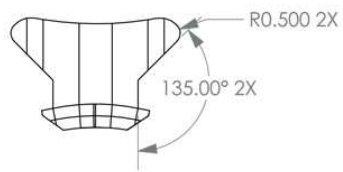
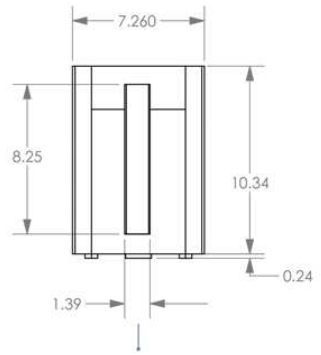





LITE UP



THE NIGHT

SUPER CAR INSPIRED MOUSE
QUICK PROJECT FOR FUN



LETS MAKE A MOUSE USING BASIC FORMS FROM EXOTIC CARS



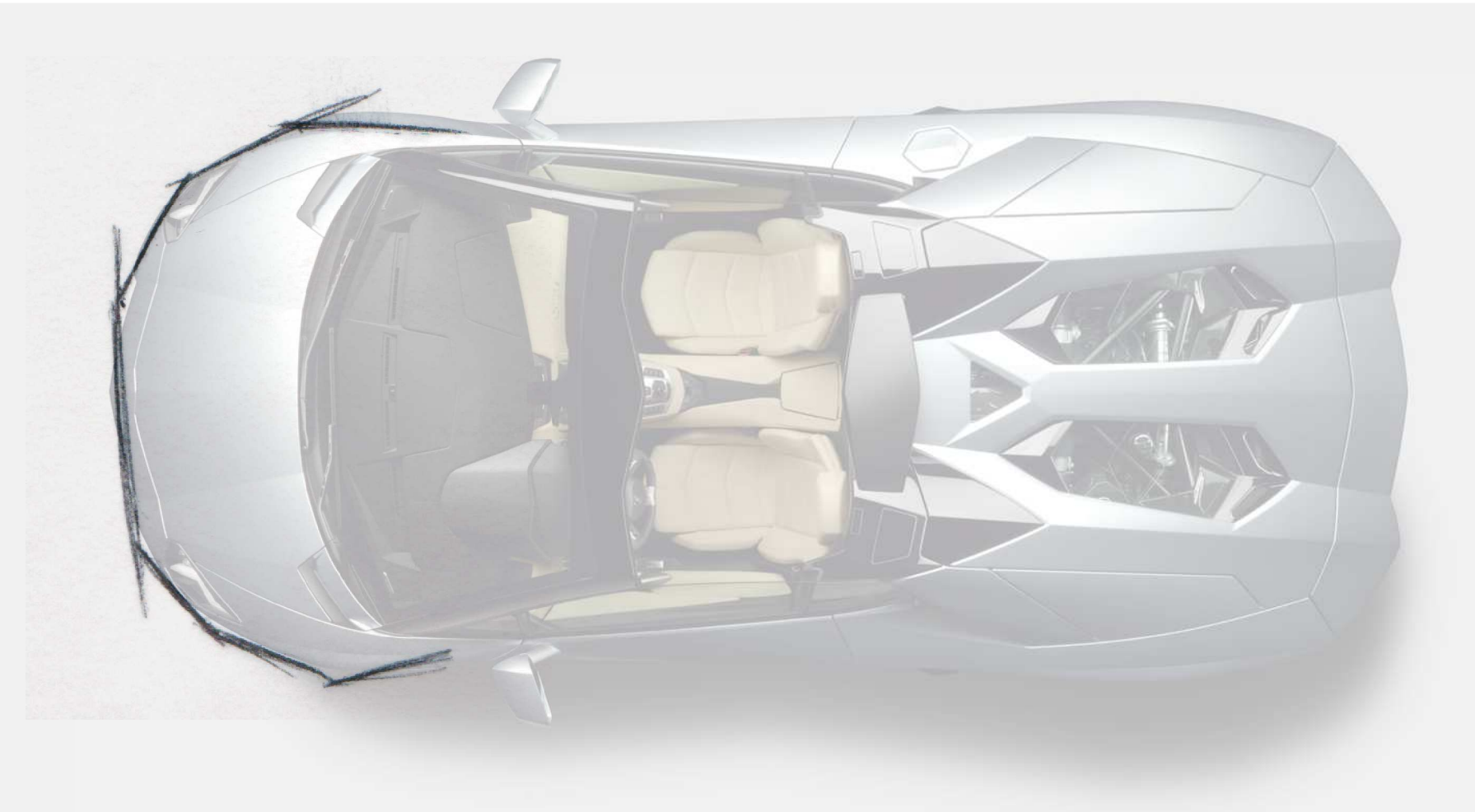

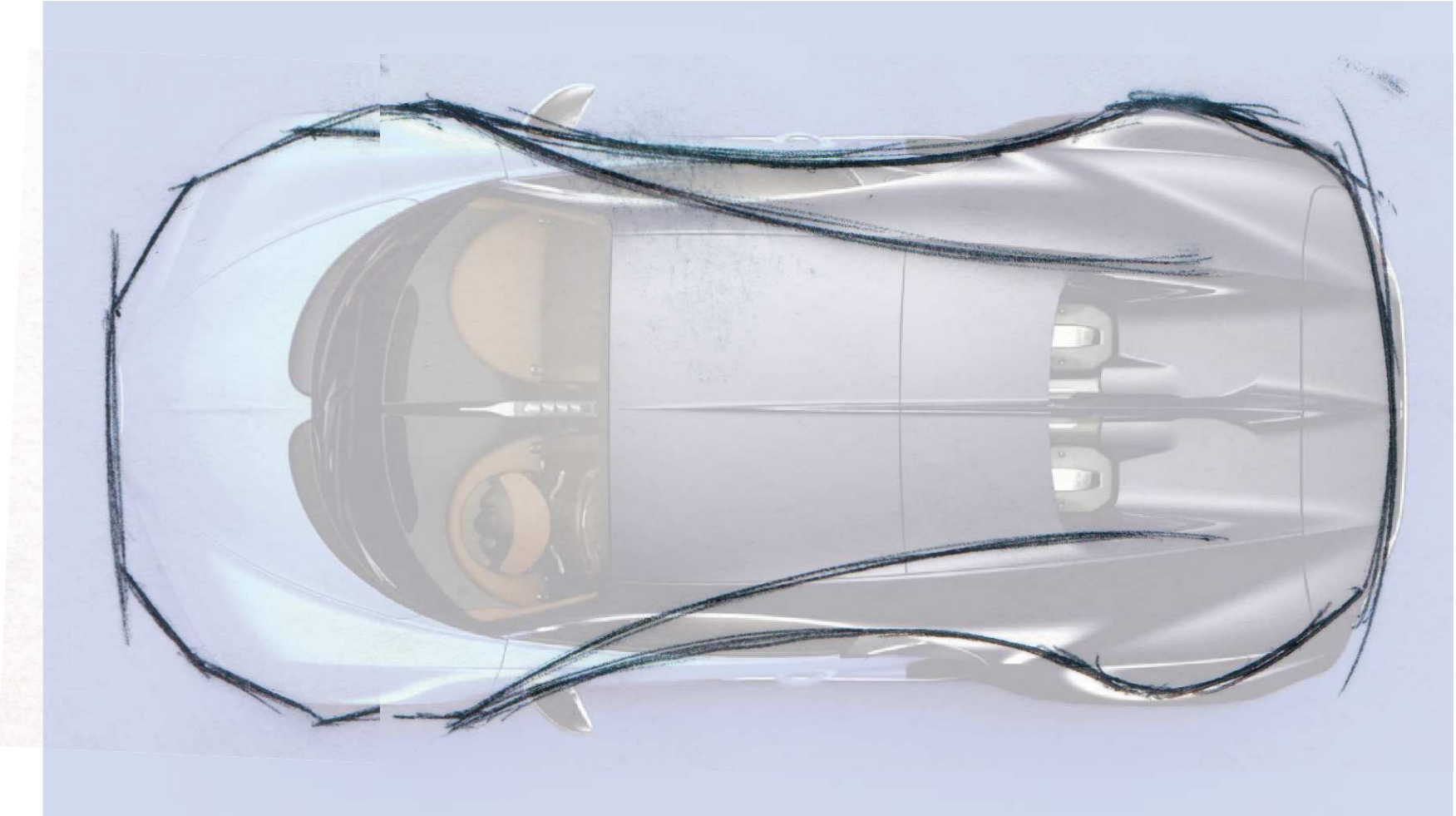

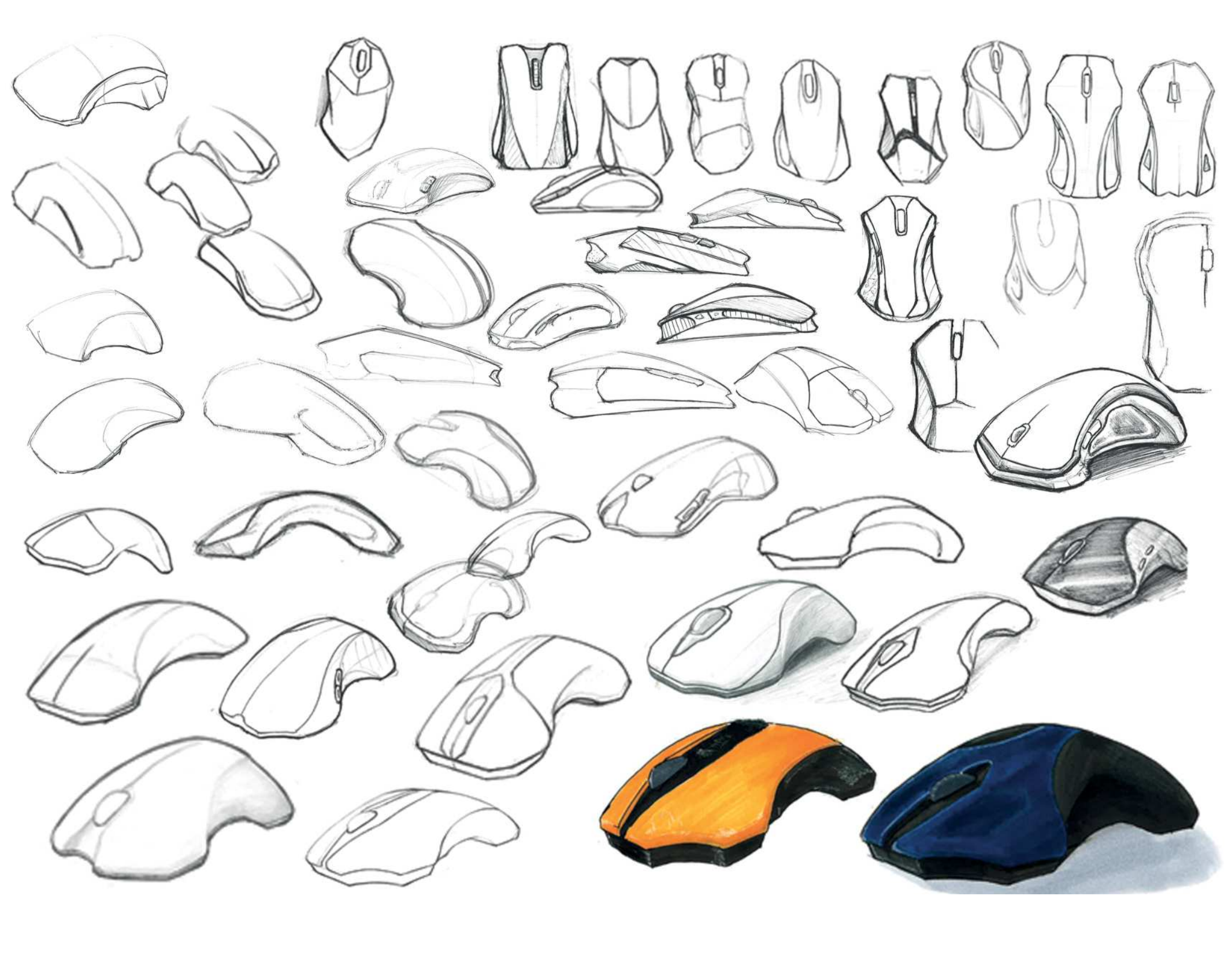





(ANIMATION CAN BE SEEN AT WWW.TIMSMITHID.COM)

TIM SMITH

TIMSMITHID@GMAIL.COM

WWW.TIMSMITHID.COM

347.404.4205

THANKS!